

Kawach Twin 150

Technology with Simplicity
Delivers..



SAFER

FASTER

RELIABLE

Saurabh Flexipack Systems Pvt Ltd

Perfect Way To Pack..

Kawach Twin 150

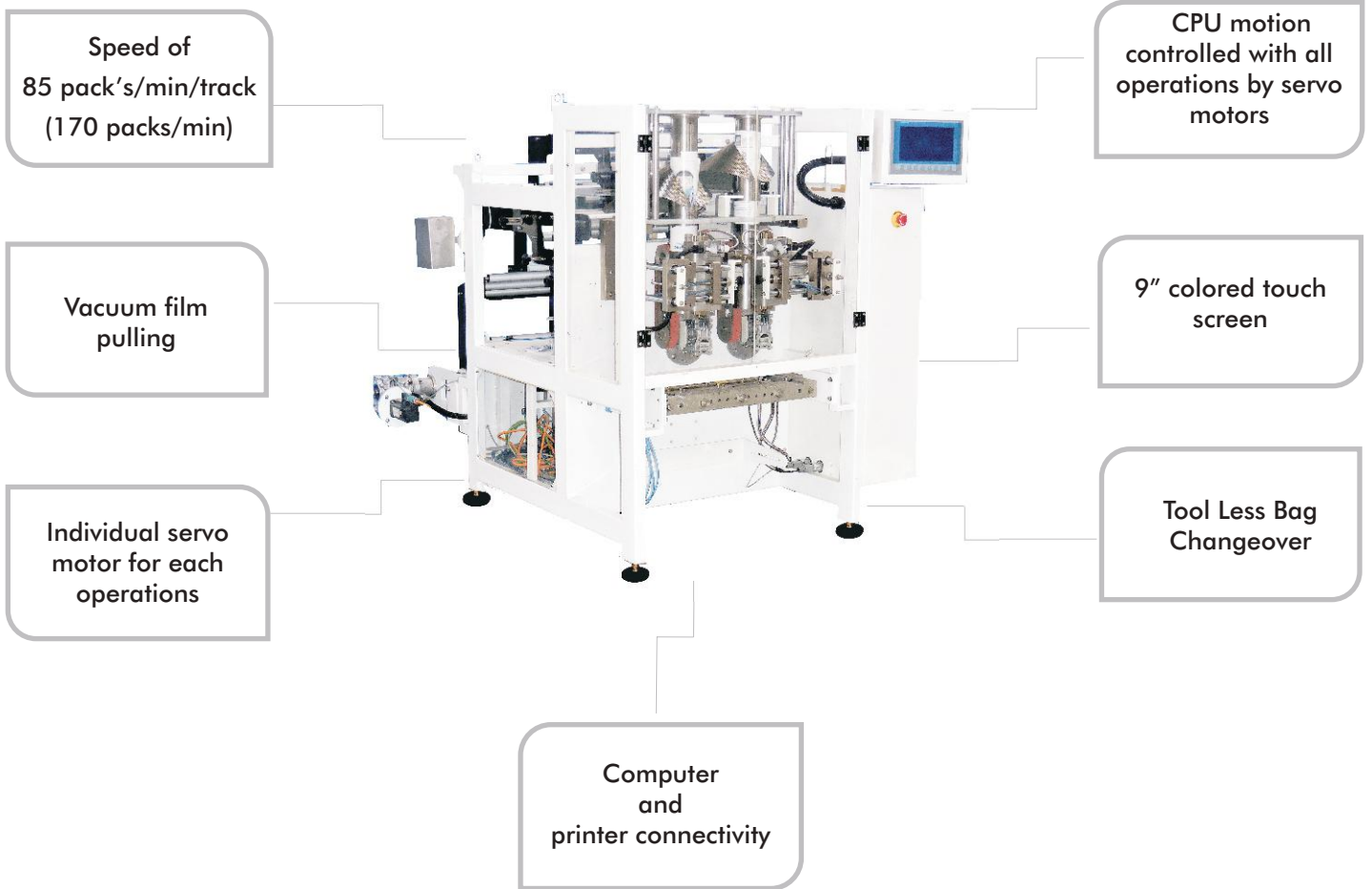

Technical Parameters

Minimum Bag width	40mm
Miximum Bag width	150mm
Miximum Bag Height	240mm
Connected Load(bagger)	3.5 Kw
Compressed Air	2 cfm at 6 bar

Machine Layout

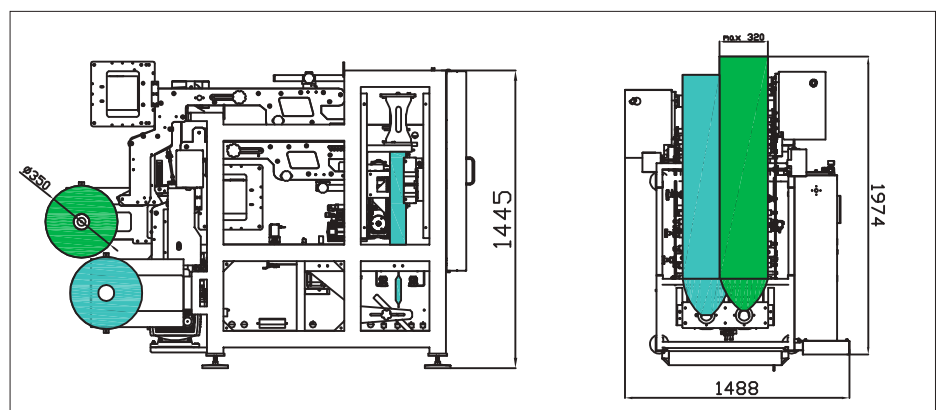

Features and Benefits

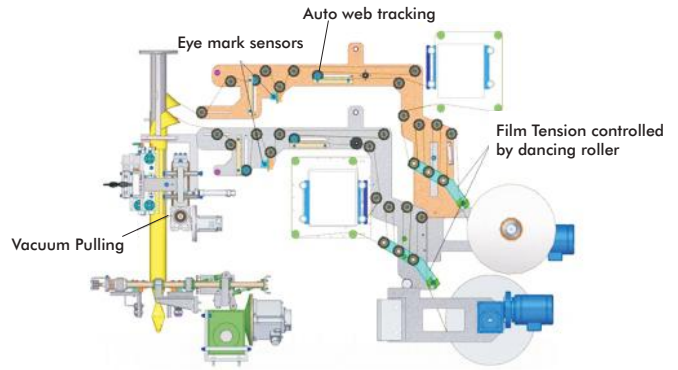
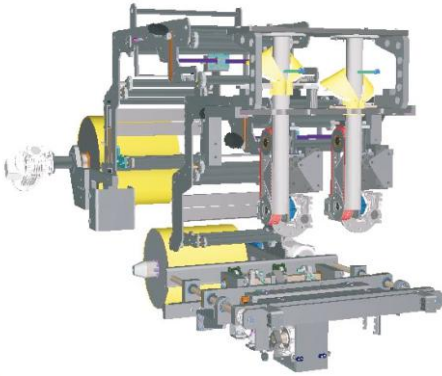

Auto film tracking

Ensure Good Pouch Finish

Tool less Former Change

Quick Change over

Light Weight Former

Easy to handle

Vacuum Belt Pulling

Ensure Good Pouch Finish

Twin Track

Make Two Different Bag Size simultaneously

CPU Motion Technology

Perfect Synchronisation and error free

Suitable Filler

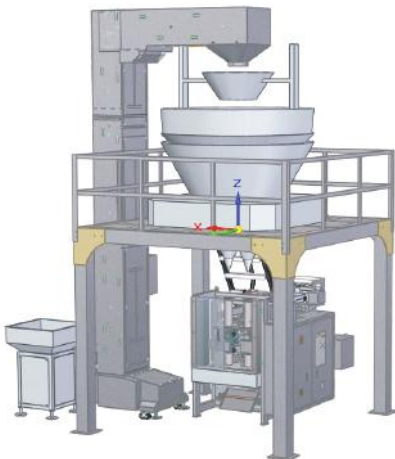

Multihead Weigher



Auger Filler

Pouch Formats



Three side seal



Center seal Bag

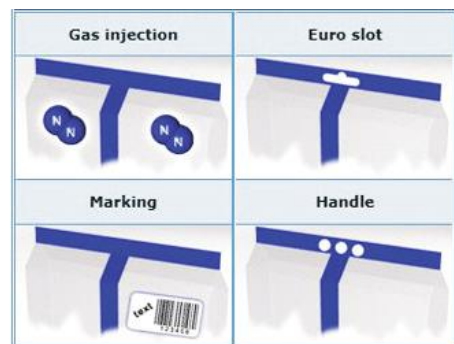

Inspired by Nature



Designed By technology



Machine Portfolio

- Contibag
- Kawach Twin 150
- Kawach 900
- Kawach 700
- Kawach 450
- Kawach 1200
- Jar Filling Line
- Pick Fill Seal Machine

Applications

- All types of Namkeen, Chips and Snacks
- All Types of Spices and Powders
- Grains and Seeds
- Pharmaceutical powder
- Viscous Products
- Chocolates and Confectionery
- Agri products
- Dairy Products

Export

- South Africa
- USA
- UAE
- Nepal
- Sri Lanka
- Bangladesh
- Kuwait
- Saudi Arabia
- Mauritius
- Kenya
- Nigeria
- Ghana
- Myanmar
- Uganda

Contact Us

Plot No-21-24, Gat.No-679/2/2, Balaji Industrial Area, Pune-Nashik Road, Alandi Phata, Kuruli-Chakan, Tal-Khed, Pune-410501, Maharashtra, INDIA
 Phone: 02135-624100 Fax: 02135-624104

Corporate- sales@saurabhflexipack.com
 mktg3@saurabhflexipack.com
 North & East - north@saurabhflexipack.com
 +91 8669985851
 South- south@saurabhflexipack.com
 +91 7447446094

